

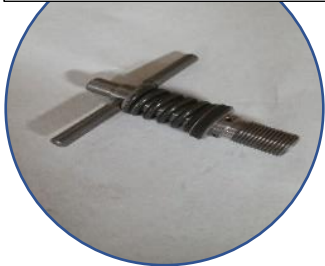

Turn-Down Bolt *TDB*(o)



TDB Components



TDB Seal (p)

Starter Switch (a)

To Reset  
(Toggle  
on/off  
Switch)

Harvard Element (q)  
*(Actual Element May Be  
Different)*



Pressure Gauge (c)

Vent  
Draincock (d)

Cover  
Clamp (e)

Outlet (g)

Drain (f)

Volume Control Valve  
(VCV) (h)

Inlet (j)

Wye Strainer (i)

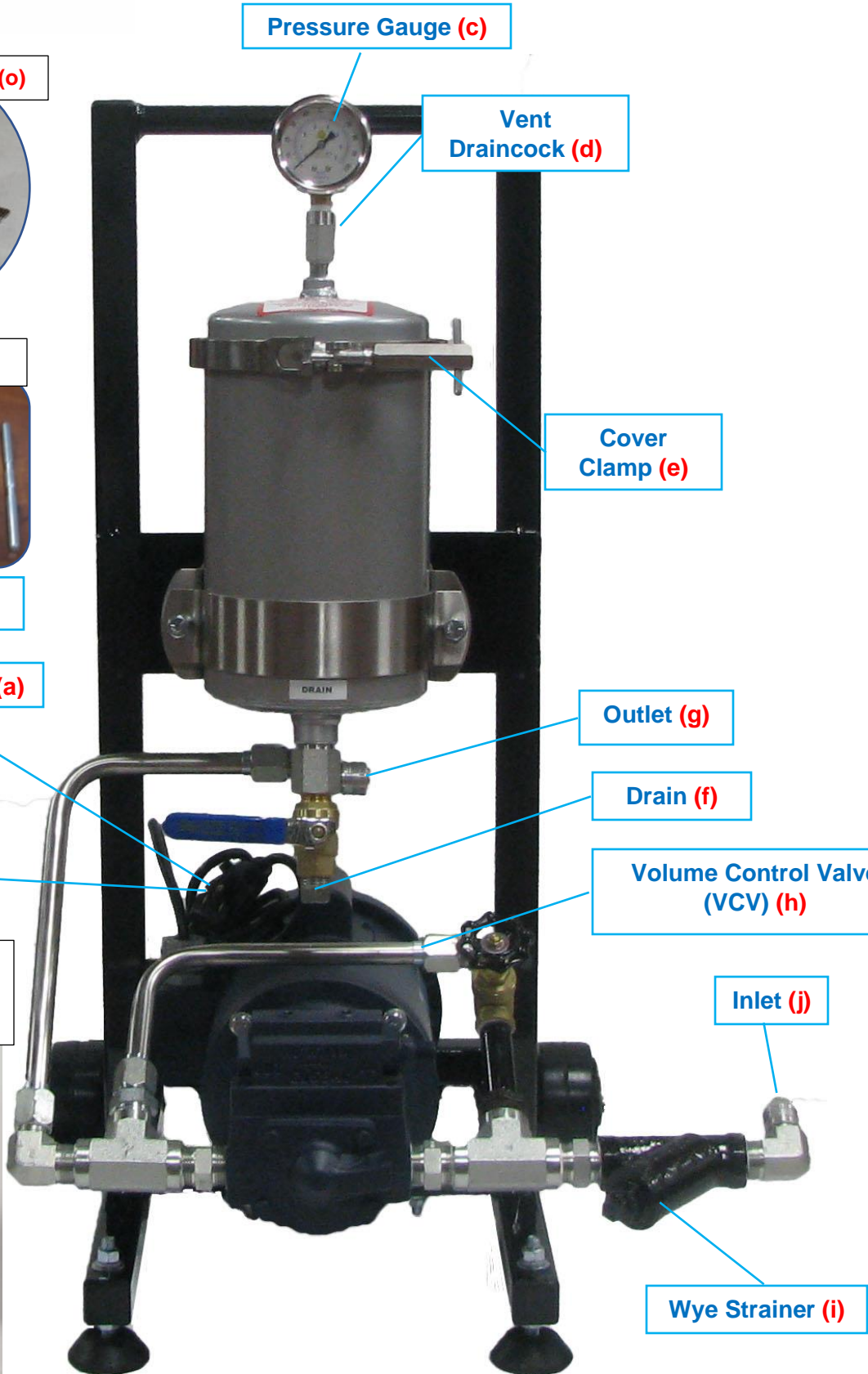

# 900088 Manual

Unless otherwise specified system does not come with elements already installed.

## Pre-Operating Instructions

- 1). Connect the inlet and outlet hoses to the inlet(j) and outlet(g) fittings, respectively.
- 2). Connect or insert the inlet line to the fluid to be cleaned, and the outlet line to the fluid to be determined.
- 3). Connect the power cord to a proper voltage and amperage as specified on the data plate *located on the back of the system* (Standard plug provided is 110/120-volt, 20-amp service).
- 4). Install the new element(q) and seal(p) per “*Element Change Procedure*” instructions.

## Operating Instructions

- 1). Turn the switch(a) on to the START system.
- 2). Rotate both the vent draincock(d) to bleed/release air; close when air released fully & oil bleeds.
- 3). Slowly close the volume control valve(h) until the pressure gauge(c) is at or above 20 PSI. *System automatically shuts down at 65 PSI.*

*-For low-viscosity fluids, the VCV(h) may need to be completely closed to operate properly*

*-For high-viscosity fluids, the VCV(h) may need to be fully opened to operate properly*

## Element Change Procedure

- 1). Turn the system off(a).
- 2). Use a suitable container to catch the fluid; position container under the drain port(f).  
*Each housing can hold up to 6 quarts of fluid.*
- 3). Remove the drain cap(f) and open the drain valve(f) at the bottom of the housing and open the vent draincock(d).
- 4). Remove the cover clamp(e) and cover.
- 5). Remove the turndown bolt, turning it counter clockwise(o).
- 6). Lift the element, using the handle and allow it to drain out in a suitable container.
- 7). Close the drain valve(f), and reinstall the drain plug.
- 8). Install the new element(q), orienting it so that the end with the handle is up.
- 9). Replace the turn-down bolt seal(p), replacement seal comes with each new element.

10). Reinstall the turn-down bolt(o). Screw it clockwise until it comes to a definite stop.

11). Reinstall the cover and cover clamp(e), and then close the vent draincock(d).

12). Your element has been changed. See the “*Wye Strainer Cleaning Instructions*” Before operating system.

## Wye Strainer Cleaning Instructions

- 1). Place a small container under the wye strainer port to catch the oil from the inlet line. The container should be able to hold the full volume of oil that is in the inlet line.
- 2). When the system is off, remove the wye strainer bolt(i) using a 15/16” wrench
- 3). Pull the screen out of the wye strainer port(i).
- 4). Clean all debris out of the screen.
- 5). Replace the cleaned screen in the wye strainer port(i).
- 6). Replace the wye strainer(i) drain bolt and tighten using a 15/16” wrench.
- 7). The wye strainer(i) has now been cleaned. See the “*Operating Instructions*” to run the system.

# System Troubleshooting Guide

## Common Problem Areas

Issue	Probable Cause	Probable Solution
<b>Motor will not start?</b>	<ol style="list-style-type: none"> <li>1. No power</li> <li>2. Faulty power switch</li> </ol>	<ol style="list-style-type: none"> <li>1. Connect to proper power source</li> <li>2. Replace power switch</li> </ol>
<b>Motor will not stay running?</b>	<ol style="list-style-type: none"> <li>1. Using 12-gauge cord or lighter</li> <li>2. Pressure not above 20 psi</li> <li>3. Pressure over 70 psi</li> </ol>	<ol style="list-style-type: none"> <li>1. Use 10-gauge cord or heavier</li> <li>2. Increase volume control valve to adjust pressure to 20 psi</li> <li>3. To high viscosity oil, filter clogged, blockage in outlet side of pump</li> </ol>
<b>Pump flow rate decreases noticeably?</b>	<ol style="list-style-type: none"> <li>1. Suction lost or blocked</li> <li>2. Wye strainer plugged</li> <li>3. Element clogged/full</li> </ol>	<ol style="list-style-type: none"> <li>1. Check supply source</li> <li>2. Clean wye strainer (see <b>system specific operating manual</b>)</li> <li>3. Replace the element (see <b>system specific operating manual</b>)</li> </ol>

## Replacement Parts Guide

See Diagram Above for Part Location	Part Description	Factory Part Number
	Pump <b>3 GPM (not flow rate)</b>	3325
	Motor $\frac{1}{2}$ <b>HP Single Phase 1140 RPM (120 v)</b>	918
	Pump & Motor Combo <b>Ships assembled</b>	
<b>c.</b>	Pressure Gauge <b>0-100 PSI Gauge</b>	841
<b>p.</b>	Turn-Down-Bolt Seal <b>Buna-N</b>	448
<b>o.</b>	Turn-Down-Bolt <b>Carbon Steel</b>	593
	Cover Gasket O-Ring <b>Buna-N</b>	433
<b>q.</b>	1002 Filter Element <b>Viscosity Iso 46-150</b>	1502
<b>q.</b>	1004 Filter Element <b>Viscosity Iso 220-1000</b>	1504

# Flow Diagram for 900088

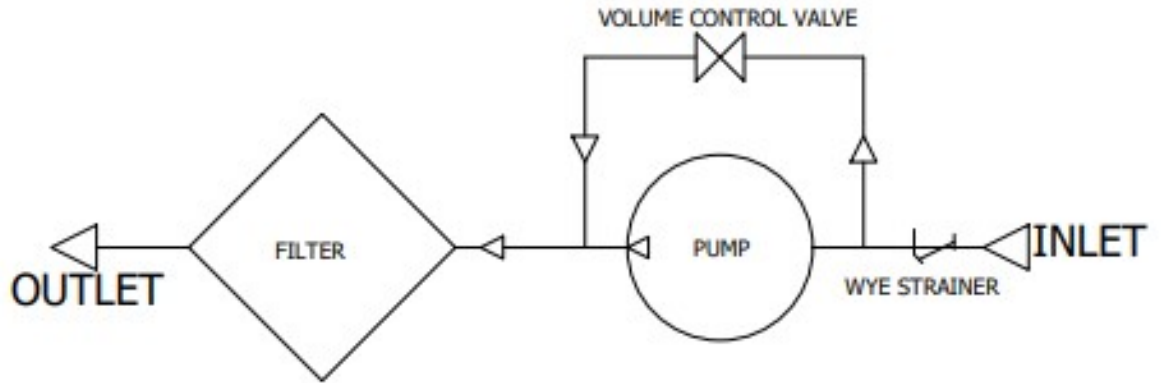

**110/120 Volt, 1 Phase**