



**Harvard Corporation**

Pressure Switch (b)

Pressure Gauge (c)

**BACK SIDE**

Starter Switch (a)

Vent Draincocks (d)



Sample Valve (n)

Cover Clamps (e)

Inlet (j)

Harvard Element (q)  
*(Actual Element May Be Different)*

Turn-Down Bolt TDB(o)

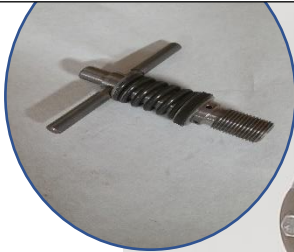

TDB Components



Drains (f)

TDB Seal (p)

Outlet (g)

Volume Control Valve "VCV" (h)

Inlet Flow Valves (m)

Harvard Bag Filter (t)

Outlet Flow Valves (l)

Transfer Valve (k)



# 900245 Manual

Unless otherwise specified, system does not come with elements already installed.

## Pre-Operating Instructions

- 1). Connect the inlet and outlet hoses to the inlet(j) and outlet(g) fittings, respectively.
- 2). Connect or insert the inlet line to the fluid to be cleaned, and the outlet line to the fluid to be determined.
- 3). Connect the power cord to a proper voltage and amperage as specified on the data plate, located on the back of the system (Standard plug provided is 110/120-volt, 20-amp service).
- 4). Install the new element(q) and seal(p) per "Element Change Procedure" instructions and the "Bag Filter Procedure" instructions.

## Operating Instructions

- 1). Open the inlet(m) and outlet(l) flow valves.
- 2). Verify the transfer valve(k) is closed
- 3). Open the volume control valve(h) (VCV).

**WARNING:** Never start the motor while the valves are closed. Damage to the motor may result and void warranty!

- 4). Move the lever on the pressure switch(b) to the START (vertical) position.

- 5). Turn the starter switch(a) to the START position.

**Factory preset! DO NOT change the setting!**

- 6). Slowly close the volume control valve(h) until the pressure gauge(c) is at or above 20 PSI. System automatically shuts down at 65 PSI.

-For low-viscosity fluids, the VCV(h) may need to be completely closed to operate properly

-For high-viscosity fluids, the VCV(h) may need to be fully opened to operate properly

- 7). Rotate both the vent draincocks(d) to bleed/release air; close when air released fully & oil bleeds.
- 8). When the pressure gauge(c) is steady at 20 PSI (after air released),

move the pressure switch lever(b) to the horizontal position.

**In transfer mode, fluid bypasses the filter element(s).** To operate in transfer mode, **close** inlet flow valves(m) and the outlet flow valves(l), volume control valve(h) and **open** the transfer valve(k).

## Element Change Procedure

- 1). Turn the system off(a).
- 2). Use a suitable container to catch the fluid; position container under the drain port(f).

*Housing can hold up to 5 gallons of fluid.*

- 3). Remove the drain cap(f) and open the drain valve(f) at the bottom of the housing and open the vent draincock(d).
- 4). Remove the cover clamp(e) and cover.
- 5). Remove the turndown bolt, turning it counter clockwise(o).

- 6). Lift the elements, using the handle or the element lifter, and allow it to drain out in a suitable container.

- 7). Close the drain valve(f), and reinstall the drain plug.

- 8). Install the new element(q), orienting them so that the end with the handle is up.

- 9). Replace the turn-down bolt seal(p), replacement seal comes with each new element.

- 10). Reinstall the turn-down bolt(o). Screw it clockwise until it comes to a definite stop.

- 11). Reinstall the cover and cover clamp(e), and then close the vent draincock(d).

- 12). Your elements have been changed. See the "**Wye Strainer Cleaning Instructions**" before operating system.

## Wye Strainer Cleaning Instructions

- 1). Place a small container under the wye strainer port to catch the oil from the inlet line. The container should be able to hold the full volume of oil that is in the inlet line.

- 2). When the system is off, remove the wye strainer bolt(i) using a 15/16" wrench

- 3). Pull the screen out of the wye strainer port(i).

- 4). Clean all debris out of the screen.

- 5). Replace the cleaned screen in the wye strainer port(i).

- 6). Replace the wye strainer(i) drain bolt and tighten using a 15/16" wrench.

- 7). The wye strainer(i) has now been cleaned. See the "**Operating Instructions**" to run the system.

## Bag Filter Change Procedure

- 1). Turn the system off(a).

- 2). Use a suitable container to catch the fluid; position container under the drain port(f).

*Each housing can hold up to 5 gallons of fluid.*

- 3). Remove the drain cap(f) of the bag filter housing and open the drain valve(f) at the bottom of the housing and open the vent draincock(d) on the cover of the bag filter housing.

- 4). Remove the cover clamp(e) and cover.

- 5). Remove the used bag filter(o) from the housing by lifting it out by the provided handle.

- 6). Close the drain valve(f), and reinstall the drain plug.

- 7). Install the new bag filter(t), orienting it so that the rim of the bag sets on the seal of the housing.

- 8). Reinstall the cover and cover clamp(e) and then close the vent draincock(d).

- 9). Your bag filter has been changed see the "**Operating Instructions**" to run the system.

## Sampling Procedure

- 1). Remove the sampling port cap(n).
- 2). Place a container beneath the sample valve to catch the oil flow. The container should hold at least one quart of fluid (.95 L)
- 3). Push in on the sample valve(n) to allow a steady stream of oil from the sample port(n).

**WARNING: Opening the sample valve knocks particles into the oil. To avoid contaminating the sample, push and hold the sample valve for several seconds before filling the sample bottle in order to flush the sample port.**

- 4). Open the sample bottle and fill it from the stream of oil.

**Keep the sample bottle upside down and the cap on until the moment you are**

**ready to take the sample, once full quickly replace the cap.**

- 5). Stop pushing the sample port(n) to close the valve.
- 6). Replace the sample valve(n) cap.
- 7). Complete the sample information sheet and send the sample into the lab to be tested.

## System Troubleshooting Guide

### Common Problem Areas

| Issue                                       | Probable Cause   | Probable Solution  |
|---|--|--|
| <b>Motor will not start?</b>                | <ol style="list-style-type: none"> <li>1. No power</li> <li>2. Faulty power switch</li> <li>3. Power switch not wired correctly</li> </ol>   | <ol style="list-style-type: none"> <li>1. Connect to proper power source</li> <li>2. Replace power switch</li> <li>3. Check wiring diagram</li> </ol>  |
| <b>Motor will not stay running?</b>         | <ol style="list-style-type: none"> <li>1. Using 12-gauge cord or lighter</li> <li>2. Lever on pressure switch not in vertical position</li> <li>3. Pressure not above 20 psi</li> <li>4. Pressure over 70 psi</li> </ol> | <ol style="list-style-type: none"> <li>1. Use 10-gauge cord or heavier</li> <li>2. Raise lever to vertical position</li> <li>3. Increase volume control valve to adjust pressure to 20 psi</li> <li>4. To high viscosity oil, filter clogged, blockage in outlet side of pump</li> </ol> |
| <b>Pump flow rate decreases noticeably?</b> | <ol style="list-style-type: none"> <li>1. Suction lost or blocked</li> <li>2. Wye strainer plugged</li> <li>3. Element clogged/full</li> </ol>   | <ol style="list-style-type: none"> <li>1. Check supply source</li> <li>2. Clean wye strainer (see <b>system specific operating manual</b>)</li> <li>3. Replace the element (see <b>system specific operating manual</b>)</li> </ol>  |

## Replacement Parts Guide

| See Diagram Above for Part Location | Part Description   | Factory Part Number |
|-------------------------------------|--|---------------------|
|                                     | Pump 5 <b>GPM (not flow rate)</b>                                    | 2204                |
|                                     | Motor $\frac{3}{4}$ <b>HP Single Phase (120 v)</b>                   | 928                 |
|                                     | Pump & Motor Combo <b>Ships assembled</b>                            | 6394                |
| <b>c.</b>                           | Pressure Gauge <b>0-100 PSI Gauge</b>                                | 841                 |
| <b>p.</b>                           | Turn-Down-Bolt Seal <b>Buna-N</b>                                    | 448                 |
| <b>o.</b>                           | Turn-Down-Bolt <b>Carbon Steel</b>                                   | 593                 |
| <b>b.</b>                           | Pressure Switch <b>Low limit 10psi – High limit 65psi (Modified)</b> | 802                 |
| <b>a.</b>                           | Starter Switch <b>(systems with serial #0913xxxx and up)</b>         | 3488                |
|                                     | Cover Gasket O-Ring <b>Buna-N</b>                                    | 433                 |
|                                     | Bag Filter O-Ring <b>Buna-N</b>                                      | 437                 |
|                                     | Bag Filter Basket 15" <b>Stainless-Steel</b>                         | 2877                |
|                                     | Vacuum Gauge 0-30  | 4304                |
|                                     | Element Lifter <b>Stainless-Steel</b>                                | 2109                |
| <b>q.</b>                           | 1002 Filter Element <b>Viscosity Iso 10-32</b>                       | 1002                |
| <b>q.</b>                           | 1004 Filter Element <b>Viscosity Iso 46-150</b>                      | 1004                |
| <b>t.</b>                           | Harvard Bag Filter   | Call/Email/Website  |

### Flow Diagram for 900245

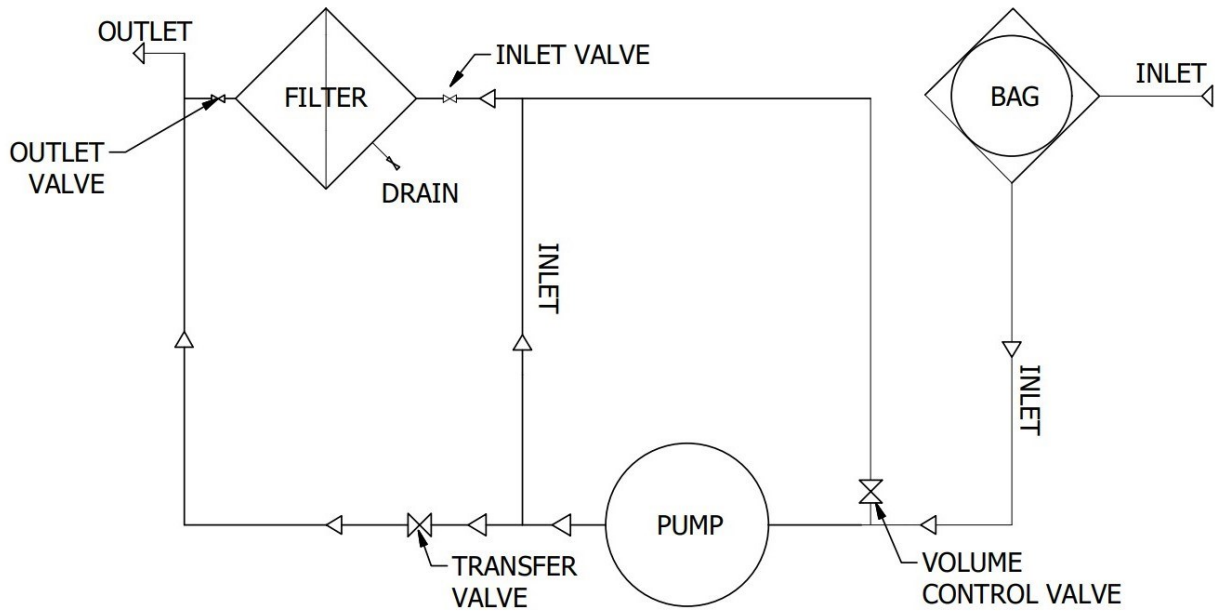

### Wiring Diagram for 900245

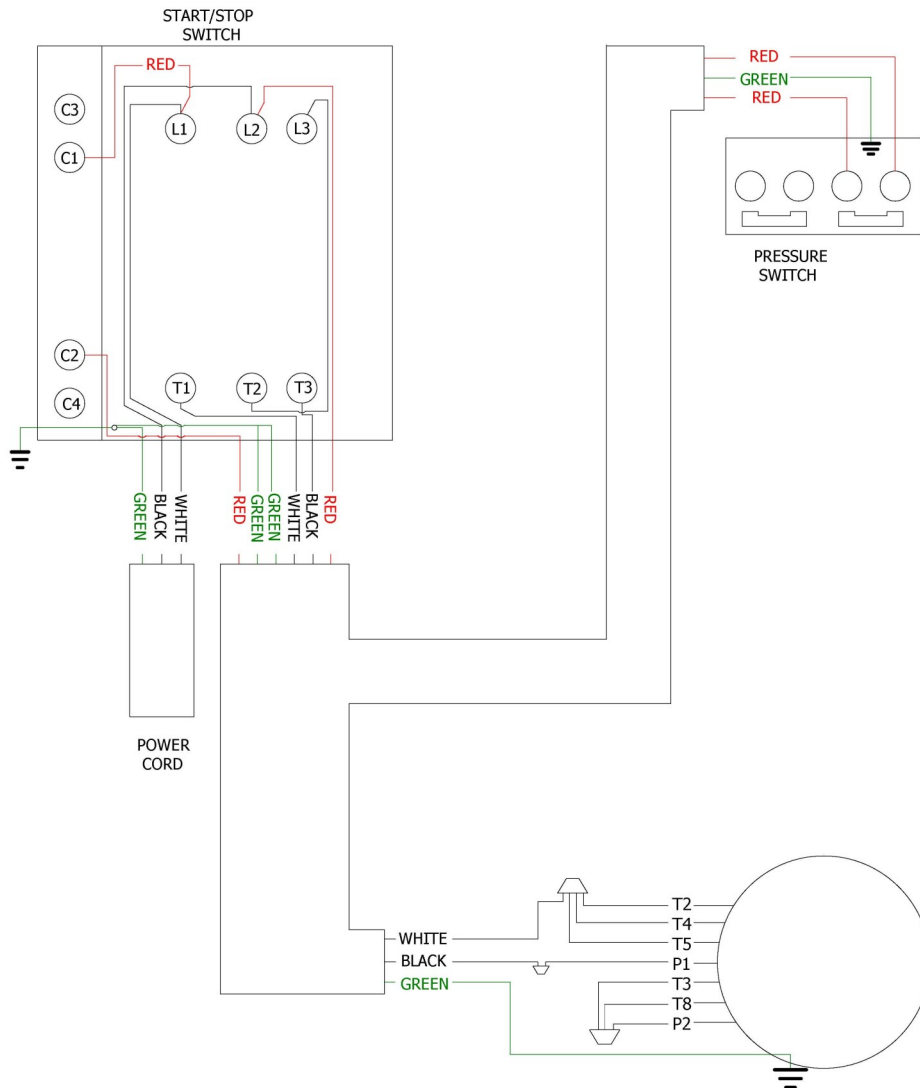

**110/120 Volt, 1 Phase**